

©Bechtel Corporation 2008. All rights reserved. Bechtel Confidential. Contains information that is confidential and proprietary to Bechtel and may not be used, copied, or disseminated without the written permission of Bechtel. This document is prepared exclusively for Gassnova in connection with the preparation of the FEED study for the CO2 Capture Facility at Karsto, Norway, and is not to be relied upon by others or used in connection with any other project.

E-110E/F/G/H
STRIPPER REBOILERS

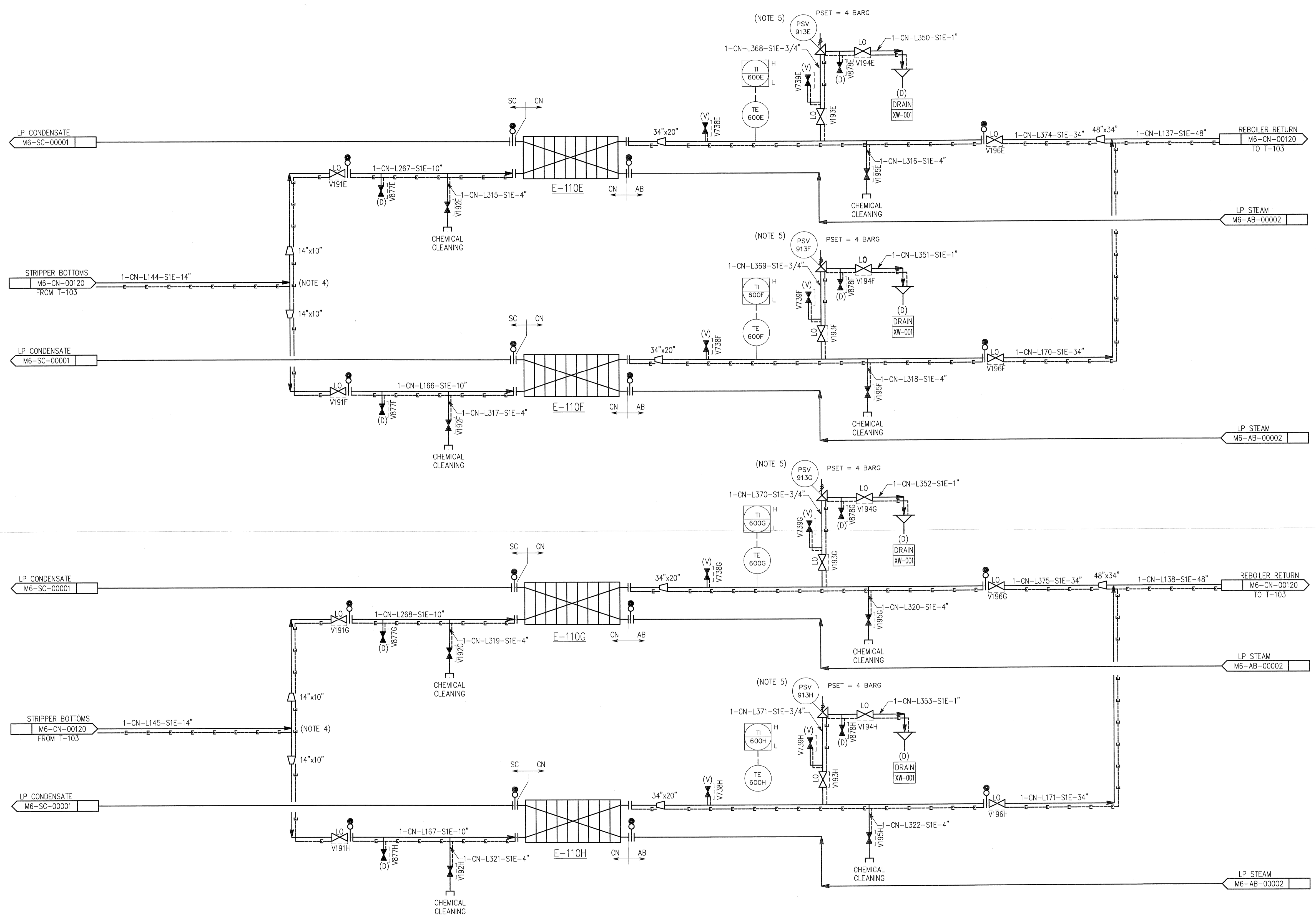

- NOTES:
- FOR SYMBOLS AND LEGENDS SEE DRAWINGS M6J-YA-00001 THROUGH M6J-YA-00005.
 - ALL LINES, VALVES, EQUIPMENT, AND INSTRUMENT NUMBERS ARE PREFIXED WITH "CN", UNLESS NOTED OTHERWISE.
 - ALL VENTS, DRAINS AND INSTRUMENTATION ROOT VALVES ARE 1", UNLESS NOTED OTHERWISE.
 - PIPING TO E-110E/F AND E-110G/H TO BE SYMMETRICAL.
 - PSV FOR THERMAL RELIEF DURING CHEMICAL CLEANING ONLY. DURING NORMAL OPERATION BLOCK VALVES IN EXCHANGER INLET/OUTLET LINES ARE TO BE LOCKED OPEN.

- HOLDS:
- CONTROL VALVES (C/V) AND PRESSURE SAFETY VALVE (PSV) SIZES.

ISSUED FOR APPROVAL		KJ	DM	-	RS	WZ
NO.	DATE	BY	CHK	DES	ENGR.	PRDR.
GASSNOVA 10112936-PB-PID-0027 Contractor		CO2 KARSTO PROJECT PIPING & INSTRUMENT DIAGRAM STRIPPER REBOILERS SHEET 2 OF 2				
		Sheet Size	594x841 "A1"	Scale	N.T.S.	
		JOB NO.	25474	DRAWING NO.	000-M6-CN-00160	REV.
						0